

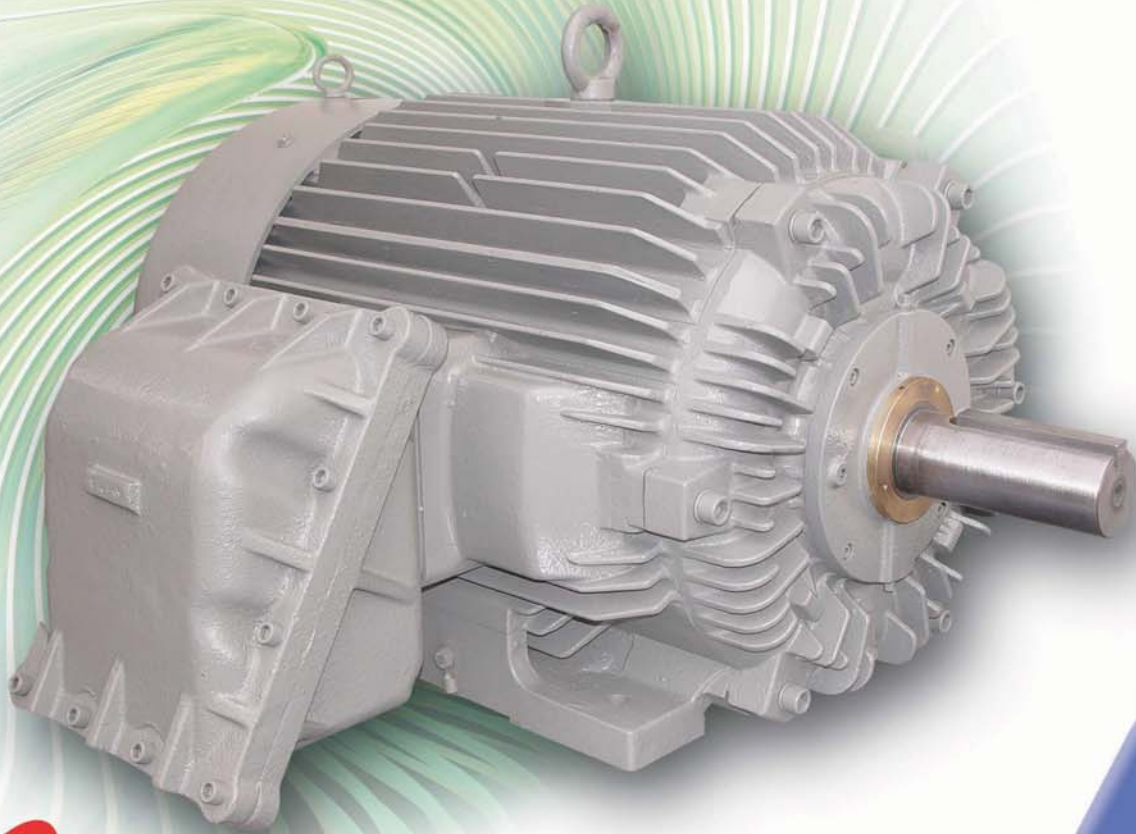

# EXPLOSION PROOF MOTORS



**NEMA STANDARD**

Frames 143T~447TZ Horizontal  
Totally-Enclosed Fan-Cooled  
Explosion Proof  
Squirrel Cage  
Induction Motors  
Hazardous Locations, Div. I  
Class I: Group D  
Class II: Groups E, F & G  
CSA EPACT energy verification NO. EEV-58484  
Explosion Proof Motors CSA Certificate No. 1077965

Listed by Underwriters Laboratories Inc.

- Quieter Operation
- Greater Sturdiness
- Stronger Frame Structure
- Inherent Corrosion Resistance
- Improved Insulation System
- Oversized Conduit Box
- Oversized Bearings (Vacuum Degassed)

UL Listed E97127

## EXPLOSION-PROOF MOTORS



These explosion proof motors are designed and approved for application in hazardous environments having certain explosive gases or materials present. They are constructed to withstand an internal explosion of gases or vapors and to prevent ignition of gases or vapors surrounding them by any internal explosion.

### Standard Features

1. 3 phase, 60 hertz, 230/460V (Usable on 208V), 575V.
2. All motors are NEMA design B, 1.15 S.F.  
F insulation at 40°C ambient, continuous duty.
3. Suitable for Division 1 locations, Class I, Group D and Class II, Groups E, F & G.
4. Rigid cast-iron frame, terminal box and fan cover provide excellent corrosion resistance, anti-vibration and stronger construction of mechanical characteristics.
5. Rotor and shaft assembly is dynamically balanced to assure vibration free, reliable and quiet operation.
6. Slings on both ends of the motor in frame 140T and above to prevent the entrance of moisture, dust, dirt or other foreign matter. (IP 55)
7. Running vibration not exceed 0.1 inch/second peak velocity for 4P, 6P and 8P, and 0.12 in/sec peak velocity for 2P motors to meet NEMA standard or better.
8. Oversized conduit box made of cast-iron provides ample space for connections; also can be rotated in 90-degree increments for convenient positioning.
9. Non-sparking, corrosion resistant, radial flow fan is quieter and more efficient.
10. Polyurethane paint system stands up to corrosive environments.
11. Stainless steel nameplate per NEMA standard.
12. Altitude: Up to 3,300 feet above sea level.
13. Listed & Labeled by Underwriters Laboratories Inc.; UL listed E97127.
14. CSA certifications and verifications, certificate no. 1077965.
15. CSA EPACT energy verification NO. EEV-58484.
16. Motor performance data is based on test in accordance with IEEE 112, method B.

# PERFORMANCE DATA

## Explosion Proof Cast Iron Frame

Energy Efficient Efficiency (EPAct)

Totally-Enclosed Fan-Cooled, Squirrel Cage, NEMA Design B

THREE Phase, 60 Hz, 230/460Volts (Usable on 208V)1.15 S.F, CLASS

F Insulation, 40Deg.C Ambient

HP	Full Load rpm	NEMA Frame	Current at 230v		Torque			NOM. F/L Eff. (%)	Efficiency			Power Factor		
			Full Load (A)	Locked Rotor (A)	Full Load (LB-FT)	Locked Rotor (%)	Break Down (%)		Full Load (%)	3/4 Load (%)	1/2 Load (%)	Full Load (%)	3/4 Load (%)	1/2 Load (%)
0.75	1140	143T	2.7	18	3.5	260	290	78.0	78.0	78.0	76.0	67.0	59.0	46.0
1	1710	143T	2.9	18	3.1	200	245	82.5	82.5	83.5	82.5	82.0	77.0	66.0
	1130	145T	3.4	18	4.6	220	240	80.0	80.0	80.0	78.0	69.0	61.0	48.0
1.5	3525	143T	4.4	32	2.1	220	270	82.5	82.5	83.0	81.0	78.0	78.0	70.0
	1715	145T	4.2	26	4.6	210	270	84.0	84.0	85.0	84.0	81.0	75.0	64.0
	1165	182T	4.6	32	6.75	260	300	85.5	85.5	86.0	84.5	71.0	63.0	50.0
2	3520	145T	5.2	45	3.0	220	260	84.0	84.0	84.0	83.0	86.0	80.0	70.0
	1715	145T	5.6	42	6.1	250	290	84.0	84.0	84.0	84.0	81.0	75.0	64.0
	1165	184T	6.2	48	9.0	270	310	86.5	86.5	86.5	84.0	71.0	63.0	50.0
3	3520	182T	7.2	64	4.47	250	370	85.5	85.5	85.5	83.5	89.0	85.0	77.0
	1735	182T	8.0	64	9.0	250	320	87.5	87.5	87.5	86.0	82.0	76.0	65.0
	1165	213T	8.9	53	13.4	200	280	87.5	87.5	87.5	86.0	72.0	65.0	52.0
5	3490	184T	11.8	92	7.5	240	340	87.5	87.5	88.0	87.0	91.0	88.5	82.5
	1735	184T	12.8	92	15.1	240	300	87.5	87.5	88.0	87.5	85.0	81.0	71.0
	1170	215T	14.6	91	22.4	210	290	87.5	87.5	87.5	86.5	74.0	67.0	55.0
7.5	3500	213T	18.8	127	11.2	240	280	88.5	88.5	89.0	88.0	85.0	84.0	78.0
	1760	213T	18.9	127	22.3	210	270	89.5	89.5	90.0	89.5	83.5	80.0	70.0
	1170	254T	20.0	125	33.7	200	260	89.5	89.5	89.5	89.0	81.5	77.5	67.5
10	3495	215T	24.0	162	15.0	240	280	89.5	89.5	89.0	88.0	87.5	86.0	82.0
	1760	215T	25.2	162	29.8	210	270	89.5	89.5	90.0	89.5	83.5	80.0	70.5
	1175	256T	26.6	161	44.7	210	280	89.5	89.5	90.0	90.0	78.5	73.5	63.5
15	3510	254T	35.2	231	22.5	200	250	90.2	90.2	89.0	88.0	91.0	89.5	85.5
	1750	254T	36.6	230	44.8	210	290	91.0	91.0	91.0	90.5	87.0	84.0	76.0
	1175	284T	40.0	210	67.2	170	240	90.2	90.2	90.5	90.0	79.5	75.5	66.0
20	3510	256T	47.0	290	29.9	200	270	90.2	90.2	90.5	90.0	90.5	89.0	85.0
	1755	256T	49.2	290	59.8	220	290	91.0	91.0	91.5	91.0	86.0	82.5	73.5
	1170	286T	52.0	282	89.7	170	240	90.2	90.2	90.5	90.0	81.0	77.5	69.0
25	3540	284TS	59.0	365	37.1	190	300	91.0	91.0	91.0	90.0	90.0	89.0	85.0
	1760	284T	62.0	360	74.5	200	250	92.4	92.4	92.5	91.0	85.5	82.5	77.0
	1175	324T	62.0	365	112	200	260	91.7	91.7	91.0	90.5	84.5	80.5	70.5
30	3535	286TS	70.0	435	44.5	190	300	91.0	91.0	91.0	90.0	91.0	89.0	86.0
	1755	286T	73.0	435	89.4	200	260	92.4	92.4	92.0	91.0	87.0	85.0	79.0
	1175	326T	72.0	435	134	210	270	91.7	91.7	92.0	91.0	86.0	82.0	73.0
40	3535	324TS	96.0	576	59.4	170	220	91.7	91.7	91.0	90.0	88.5	87.0	85.0
	1765	324T	96.0	580	119	200	270	93.0	93.0	93.0	91.5	86.5	85.0	79.0
	1175	364T	95.6	580	178	170	280	93.0	93.0	92.0	91.0	86.0	83.0	76.5
50	3550	326TS	120	725	74.2	180	220	92.4	92.4	91.5	90.0	86.5	85.0	80.5
	1765	326T	118	725	148	200	270	93.0	93.0	93.0	91.5	86.5	85.0	79.0
	1175	365T	116	720	223	170	280	93.0	93.0	92.0	91.0	87.0	84.0	77.0
60	3550	364TS	137	870	88.5	160	220	93.0	93.0	93.5	93.0	88.5	87.0	82.0
	1770	364T	144	870	178	170	260	93.6	93.6	93.5	93.0	84.0	82.5	76.0
	1180	404T	140	870	267	220	250	93.6	93.6	93.7	93.2	87.0	84.0	76.0
75	3560	365TS	170	1080	111	160	220	93.0	93.0	93.5	93.0	89.0	88.0	84.0
	1770	365T	178	1085	223	175	250	94.1	94.1	94.0	94.0	85.0	83.0	76.0
	1180	405T	174	1085	334	220	250	93.6	93.6	93.7	93.5	88.0	85.0	78.0
100	3560	405TS	230	1450	148	165	230	93.6	93.6	93.0	93.0	87.0	86.0	80.0
	1775	405T	242	1450	296	180	240	94.5	94.5	93.0	93.0	83.0	78.0	67.0
	1180	444T	244	1450	445	180	260	94.1	94.1	93.5	93.0	82.5	80.5	73.0
125	3550	444TS	292	1815	185	160	220	94.5	94.5	93.0	93.0	86.5	84.5	77.0
	1775	444T	290	1815	370	180	230	94.5	94.5	93.5	93.5	87.0	85.0	81.0
	1180	445T	302	1815	556	180	250	94.1	94.1	93.5	93.5	83.0	81.0	74.0
150	3550	445TS	346	2170	222	160	220	94.5	94.5	93.0	93.0	87.0	84.5	78.0
	1780	445T	338	2170	443	175	230	95.0	95.0	94.0	93.5	88.0	87.0	83.0
	1180	447TZ	358	2170	668	185	235	95.0	95.0	94.0	93.5	83.5	81.0	74.0
200	3560	447TS	228	1450	295	160	220	95.0	95.0	93.5	93.0	87.5	85.5	79.0
	1780	447TZ	226	1450	590	175	230	95.0	95.0	94.0	93.5	89.0	87.5	83.0

Note: 1. The above are typical values based on test.

3. For 200HP and larger are 460 volts only.

5. For current of 460 volts, divide above values by 2. (Currents of 200HP and larger based on 460 volts)

2. Actual test data per IEEE-112 method B.

4. 208V usable on identified value.

All data/dimensions subject to change without prior notice.

# Premium Features are Standard on Tatung NEMA Explosion Proof Motors

## 1. Class F Insulation System

The class F insulation material was selected to give maximum protection against temperature, corrosion, abrasion and moisture-benefits that assure long life.

All motors are furnished with temperature detectors.

## 2. Oversized Bearings of Vacuum Degassed Steel

You can be assured of long life and quiet operation.

Suitable for use over a large range of applications.

## 3. Non-Sparking Brass Slinger

In order to meet the class II Group E specification non-sparking brass slingers are furnished on both end shaft paths to prevent dust getting into bearings.

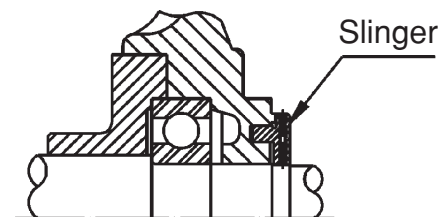

## 4. Oversized Cast Iron Conduit Box

Conduit box is rugged, corrosion-resistant cast iron.

Large diagonally split construction assures explosion and dust tightness and has plenty of room to make power connections. Leads are securely held with a sealing compound where they pass into the motors case.

Conduit box can be located on either side of motor and easily rotated for 90 deg. positions so that conduit can be received from any direction.

## 5. Fan and Fan Cover

The external fan is constructed of non-sparking and corrosion-resistant materials.

The fan cover is of corrosion-resistant cast iron.

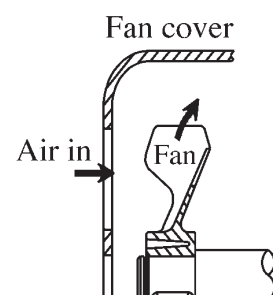

## 6. Distortion-Free Frame and End Shields

Corrosion-resistant finished high grade cast iron frame and end shields have enough strength against required explosion pressure and are machined to close tolerances to insure required explosion paths.

## 7. Stainless Steel Nameplate

An easily read and long life corrosion-resistant stainless steel nameplate complete with connection diagrams.

## 8. Efficient Stainless Steel Breather and Drains

Specially designed breather and drain plugs are provided to alleviate condensation.

They meet all requirements for hazardous atmospheres.

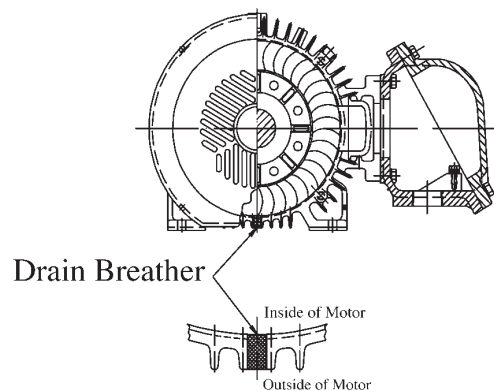

## Tatung Explosion Proof Motors for Hazardous Locations Listed by UL & CSA

- CLASS I** Atmosphere in which flammable gases or vapors are or may be present in the air in quantities sufficient to produce explosion or ignite mixtures.
- GROUP D** Atmospheres containing gasoline, hexane, naphtha, benzene, butane, propane, alcohols, acetone, benzol, lacquer solvent vapors, or natural gas.
- CLASS II** Those which are hazardous because of the presence of combustible dust.
- GROUP E** Atmospheres containing dust of aluminum, magnesium, or their commercial alloys.
- GROUP F** Atmospheres containing carbon black, coal or coke dust.
- GROUP G** Atmospheres containing flour, starch or grain dust.

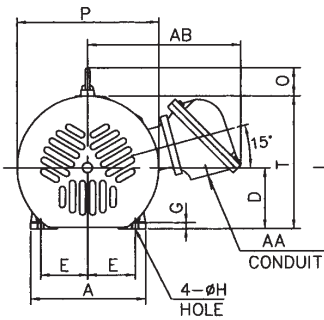

FIG. 1

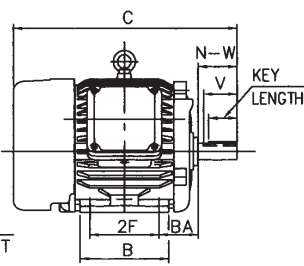

FIG. 2

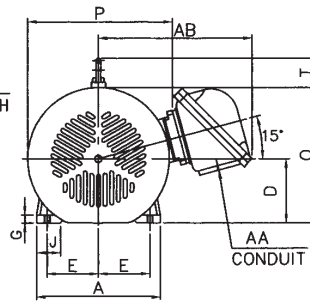

FIG. 4

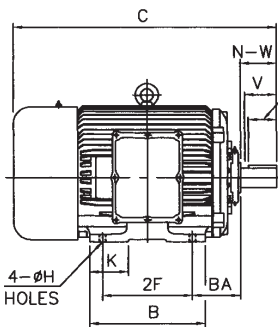
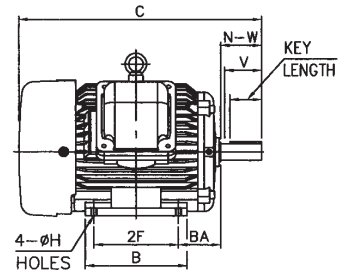
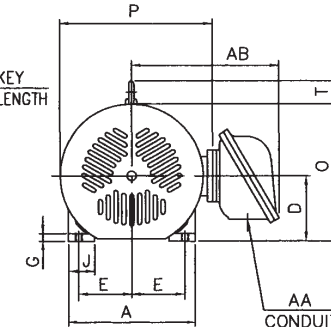

FIG. 5



FRAME NO.	FIG. NO.	MOUNTING			BA	A	B	C	D	G	J	K	P	O+T
		E	2F	øH										
143T	1	2.75	4.00	0.34	2.25	6.69	5.12	12.95	3.50	0.35	—	—	8.40	9.30
145T		2.75	5.00	0.34	2.25	6.69	6.10	13.94	3.50	0.35	—	—	8.40	9.30
182T		3.75	4.50	0.43	2.75	9.05	5.75	15.11	4.50	0.66	—	—	9.84	11.45
184T		3.75	5.50	0.43	2.75	9.05	6.69	16.09	4.50	0.66	—	—	9.84	11.45
213T	2	4.25	5.50	0.41	3.50	10.23	7.09	18.54	5.25	0.65	1.97	—	11.97	12.49
215T		4.25	7.00	0.41	3.50	10.23	8.39	20.11	5.25	0.65	1.97	—	11.97	12.49
254T	3	5.00	8.25	0.53	4.25	12.36	9.84	23.88	6.25	0.75	2.36	—	13.19	15.04
256T		5.00	10.00	0.53	4.25	12.36	11.81	25.61	6.25	0.75	2.36	—	13.19	15.04
284T	4	5.50	9.50	0.55	4.75	13.78	12.00	26.72	7.00	0.78	3.00	3.54	17.36	17.63
284TS		5.50	9.50	0.55	4.75	13.78	12.00	25.35	7.00	0.78	3.00	3.54	17.36	17.63
286T		5.50	11.00	0.55	4.75	13.78	13.50	28.22	7.00	0.78	3.00	3.54	17.36	17.63
286TS		5.50	11.00	0.55	4.75	13.78	13.50	26.85	7.00	0.78	3.00	3.54	17.36	17.63
324T		6.25	10.50	0.66	5.25	14.88	12.68	29.91	8.00	1.23	3.15	3.15	18.82	19.42
324TS		6.25	10.50	0.66	5.25	14.88	12.68	28.41	8.00	1.23	3.15	3.15	18.82	19.42
326T		6.25	12.00	0.66	5.25	14.88	14.17	31.41	8.00	1.23	3.15	3.15	18.82	19.42
326TS		6.25	12.00	0.66	5.25	14.88	14.17	29.91	8.00	1.23	3.15	3.15	18.82	19.42
364T	5	7.00	11.25	0.66	5.88	16.40	14.40	32.94	9.00	1.32	3.15	4.73	20.35	22.17
364TS		7.00	11.25	0.66	5.88	16.40	14.40	30.81	9.00	1.32	3.15	4.73	20.35	22.17
365T		7.00	12.25	0.66	5.88	16.40	15.40	33.92	9.00	1.32	3.15	4.73	20.35	22.17
365TS		7.00	12.25	0.66	5.88	16.40	15.40	31.79	9.00	1.32	3.15	4.73	20.35	22.17
404T	6	8.00	12.25	0.81	6.62	19.13	16.18	39.32	10.00	1.54	3.94	5.91	23.60	24.54
405T		8.00	13.75	0.81	6.62	19.13	17.68	40.81	10.00	1.54	3.94	5.91	23.60	24.54
405TS		8.00	13.75	0.81	6.62	19.13	17.68	37.81	10.00	1.54	3.94	5.91	23.60	24.54
444T		9.00	14.50	0.81	7.50	22.05	17.32	46.57	11.00	1.37	4.33	4.72	25.83	26.54
444TS		9.00	14.50	0.81	7.50	22.05	17.32	42.82	11.00	1.37	4.33	4.72	25.83	26.54
445T		9.00	16.50	0.81	7.50	22.05	19.29	48.58	11.00	1.37	4.33	4.72	25.83	26.54
445TS	9.00	16.50	0.81	7.50	22.05	19.29	44.83	11.00	1.37	4.33	4.72	25.83	26.54	
447TZ	6	9.00	20.00	0.81	7.50	22.05	22.83	59.54	11.00	1.37	4.33	6.50	25.83	26.54
447TS		9.00	20.00	0.81	7.50	22.05	22.83	54.67	11.00	1.37	4.33	6.50	25.83	26.54

Note: 1. Tolerance on dimension D: +0.00 inch, -0.03 inch for frame 143~184. +0.00 inch, -0.06 inch for frame 213~447.  
 2. Tolerance on dimension U: +0.000 inch, -0.0005 inch for frame 143~215. +0.000 inch, -0.001 inch for frame 254~447.  
 3. Tolerance on dimension R: +0.000 inch, -0.015 inch.  
 4. Dimension V is length of straight part shaft.

All data/dimensions subject to change without prior notice.

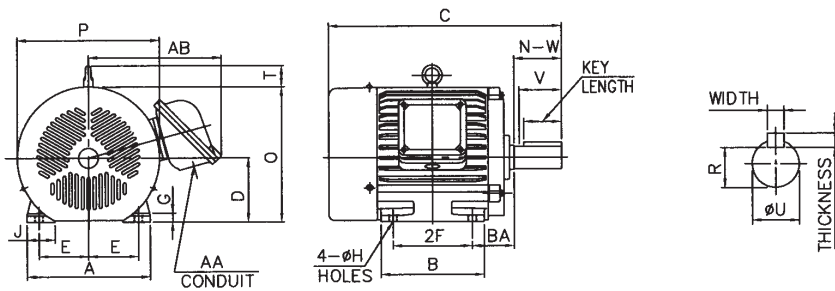

FIG. 3

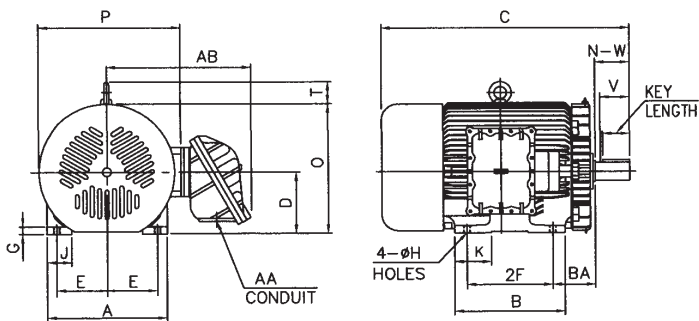

FIG. 6

3RD ANGLE PROJECTION / DIMENSIONS IN INCHES

KEY			KEYSEAT R	CONDUIT BOX		SHAFT EXTENSION			BEARINGS		APPR.WT (LBS.)	FRAME NO.
WIDTH	THICKNESS	LENGTH		AA	AB	N-W	ØU	V	DRIVE END	OPPOSITE DRIVE END		
0.188	0.188	1.375	0.771	NPT 3/4	8.74	2.25	0.875	2.20	6205ZZ	6205ZZ	48	143T
0.188	0.188	1.375	0.771	NPT 3/4	8.74	2.25	0.875	2.20	6205ZZ	6205ZZ	56	145T
0.250	0.250	1.77	0.984	NPT1	9.57	2.75	1.125	2.70	6207ZZ	6206ZZ	100	182T
0.250	0.250	1.77	0.984	NPT1	9.57	2.75	1.125	2.70	6207ZZ	6206ZZ	110	184T
0.312	0.312	2.375	1.201	NPT1	12.69	3.38	1.375	3.30	6308ZZ	6208ZZ	286	213T
0.312	0.312	2.375	1.201	NPT1	12.69	3.38	1.375	3.30	6308ZZ	6208ZZ	286	215T
0.375	0.375	2.91	1.416	NPT1 1/4	12.75	4.00	1.625	3.90	6310ZZ	6208ZZ	374	254T
0.375	0.375	2.91	1.416	NPT1 1/4	12.75	4.00	1.625	3.90	6310ZZ	6208ZZ	418	256T
0.500	0.500	3.28	1.591	NPT1 1/2	17.52	4.62	1.875	4.50	6310	6310	527	284T
0.375	0.375	1.91	1.416	NPT1 1/2	17.52	3.25	1.625	3.20	6310C3	6310C3	545	284TS
0.500	0.500	3.28	1.591	NPT1 1/2	17.52	4.62	1.875	4.50	6310	6310	580	286T
0.375	0.375	1.91	1.416	NPT1 1/2	17.52	3.25	1.625	3.20	6310C3	6310C3	580	286TS
0.500	0.500	3.91	1.845	NPT2	18.31	5.25	2.125	5.00	6312	6312	711	324T
0.500	0.500	2.03	1.591	NPT2	18.31	3.75	1.875	3.50	6312C3	6312C3	710	324TS
0.500	0.500	3.91	1.845	NPT2	18.31	5.25	2.125	5.00	6312	6312	825	326T
0.500	0.500	2.03	1.591	NPT2	18.31	3.75	1.875	3.50	6312C3	6312C3	800	326TS
0.625	0.625	4.28	2.021	NPT3	20.20	5.88	2.375	5.75	6215	6312	1100	364T
0.500	0.500	2.03	1.591	NPT3	20.20	3.75	1.875	3.50	6312C3	6312C3	1135	364TS
0.625	0.625	4.28	2.021	NPT3	20.20	5.88	2.375	5.75	6215	6312	1200	365T
0.500	0.500	2.03	1.591	NPT3	20.20	3.75	1.875	3.50	6312C3	6312C3	1187	365TS
0.750	0.750	5.65	2.450	NPT3	23.03	7.25	2.875	7.00	6318	6313	1413	404T
0.750	0.750	5.65	2.450	NPT3	23.03	7.25	2.875	7.00	6318	6313	1513	405T
0.500	0.500	2.78	1.845	NPT3	23.03	4.25	2.125	4.00	6313C3	6313C3	1513	405TS
0.875	0.875	6.875	2.880	NPT3	24.02	8.50	3.375	8.25	6320	6318	2010	444T
0.625	0.625	3.000	2.021	NPT3	24.02	4.75	2.375	4.50	6314C3	6314C3	2010	444TS
0.875	0.875	6.875	2.880	NPT3	24.02	8.50	3.375	8.25	6320	6318	2120	445T
0.625	0.625	3.000	2.021	NPT3	24.02	4.75	2.375	4.50	6314C3	6314C3	2120	445TS
0.875	0.875	8.500	2.880	NPT3 1/2	24.02	10.125	3.375	9.875	6320	6318	2840	447T
0.625	0.625	3.000	2.021	NPT3 1/2	24.02	4.75	2.375	4.50	6314C3	6314C3	2840	447TS

All 2-pole motors are used for direct-coupled drive only. For belted driving, please contact TATUNG CO.

3-42963

(Fr143T~447TZ)

AN EXPLODED VIEW OF EXPLOSION-PROOF MOTOR

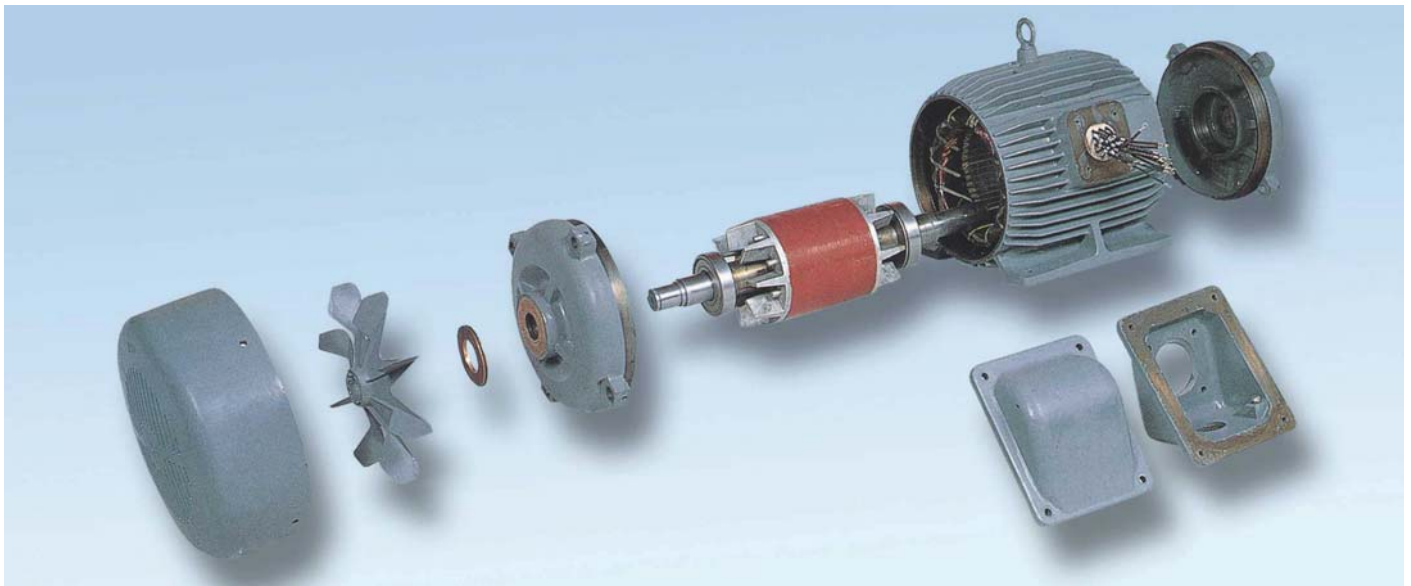

TEST TANK

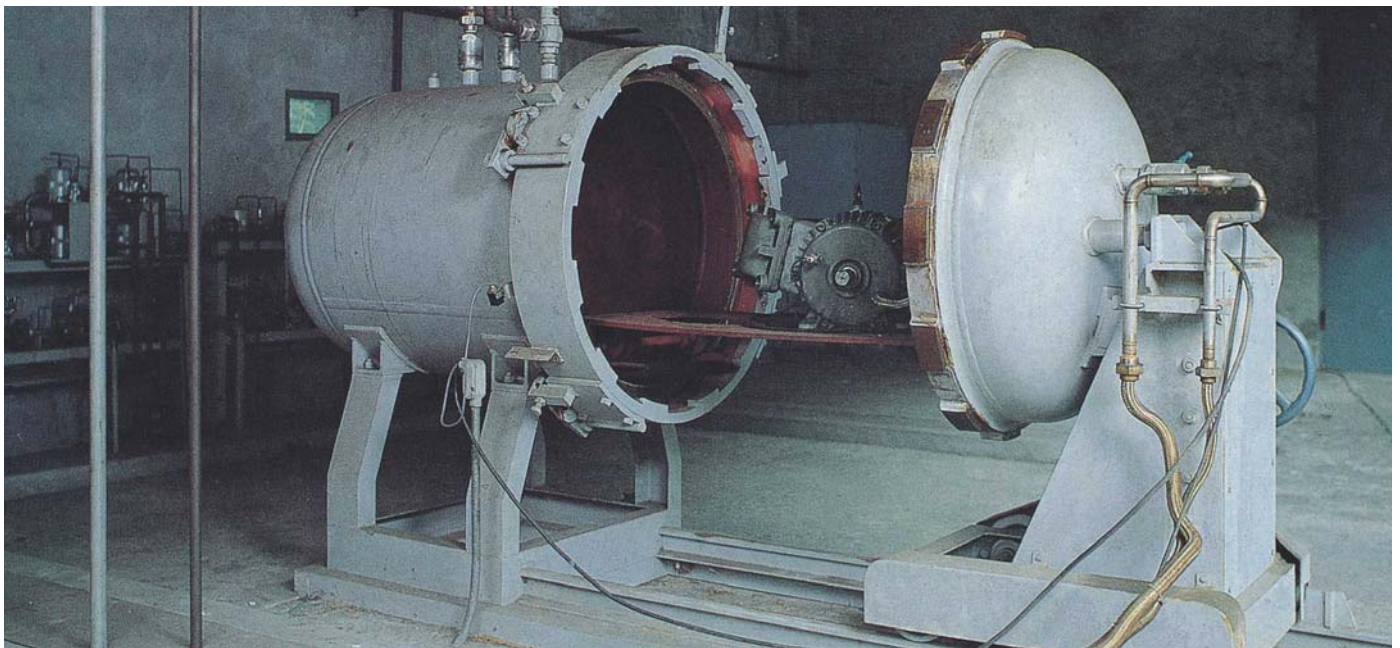

**TATUNG Electric Company of America, Inc.**

14381 CHAMBERS ROAD TUSTIN, CA. 92780  
Tel: 714-8383293 Fax: 714-8383295  
E-mail Address: sales@tatungelectric.com  
Call Toll Free 800-828-8641



**TATUNG CO.**

22 Chungshan North Road, 3rd Sec. Taipei, Taiwan, 10451, R. O. C.  
Tel: (886-2) 25925252  
Fax: (886-2) 2591-5185/2592-1813  
<http://www.tatung.com>

**Sanhsia Plant (Motor Plant)**

352 Shi-Tong Rd., San-Hsia, County Taipei Hsien, Taiwan, 237, R.O.C.  
Tel: (886-2) 8676-6888 Fax:(886-2) 8676-5050  
<http://www.tatung.com/heavy>



2003.10.No.107031E